

U-LZ150

Z Bracket for U10003F-S

- Manufactured from anodised aluminium for enhanced strength and durability
- Designed specifically for in-swing door applications
- Quick and easy to install
- Mounting accessory for 300lb electromagnetic locks
- Ensures the magnet remains securely on the protected side of the door

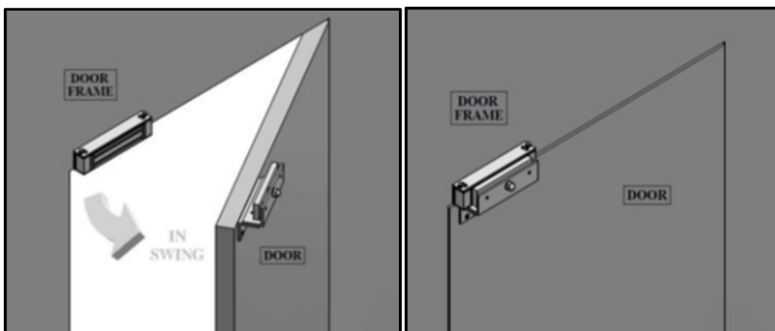

Installation Diagram

Total Weight :0.34kg

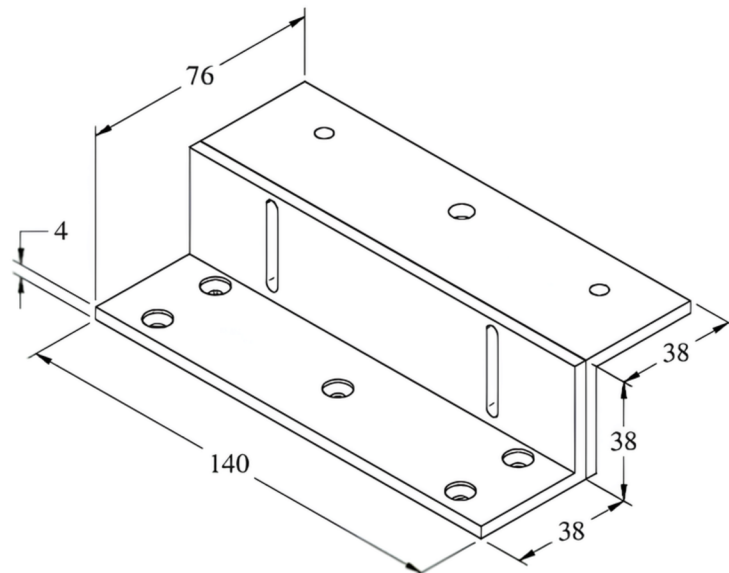

Dimension : 140mm (L) x 76mm (W)
Thickness : 4mm