

YD30S

Electric Lock



BS EN1634:1

- Operating voltage 12~24Vdc (*Selectable*)
- Aluminium housing
- Holding force up to 2 x 600lbs (272Kg)
- Electro-less Nickel Plated Armature
- Status LED ● Red ● Green
- Tested to FD30 & FD60

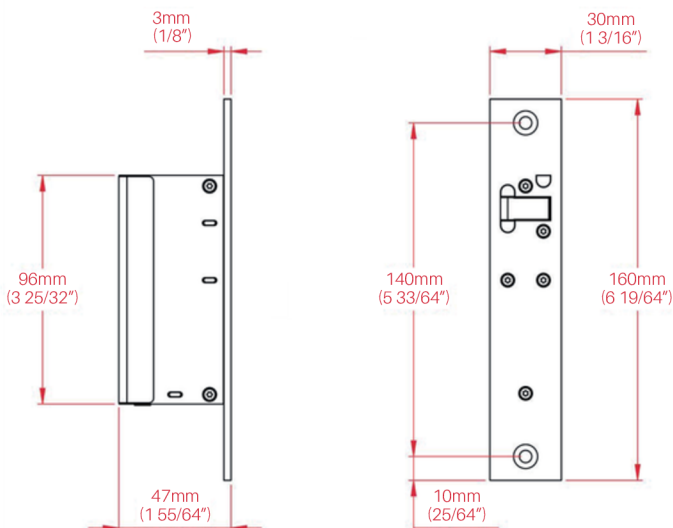

Door Gap

6mm (1/4 inch) maximum

Static strength

10,000N (2,250 lbf)

Sideload (release on request)

6,000N (1,350 lbf)

Endurance

Cycle tested to 1,000,000 operations

Bolt Pin

10mm (3/8 inch) thick,
13mm (1/2 inch) extension

Alignment

8mm (5/16 inch) misalignment correction

Voltage at lock

12-24VDC ±15%

Current usage

Holding: 40mA@12VDC,
25mA@24VDCMaximum: 0.75A@12VDC,
0.4A@24VDC

Monitor switch ratings

30VDC max, 100mA max

Materials

Lock/Strike Plate: Stainless
Steel 304

Bolt Pin: Stainless Steel 17-4PH

Environment

IP53

Compliance & Certification

- CE Compliant, RoHS 2 Compliant
- FCC Part 15 / IC Compliant
- RCM Compliant, UL Listed
- EN 14846:2008 Certified
- Suitable for use on fire resistant doorsets