

UL275SL MONITORED

ECO Low Current Mini Magnet

- Operating voltage 12~24Vdc (*Selectable*)
- 250mA @12VDC 130mA @24VDC
- Holding force up to 600lbs (272Kg)
- Aluminium housing
- Electroless Nickel Plated Armature
- Fail-Safe
- Door status: An independent contact that works separately from the magnet to show door status not lock status
- Status LED ● Red ● Green



OPTIONS

300BP

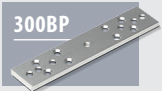

U320M



U300ZL



300ZLDC



U300AL



UGDB14



LD-MM-SC

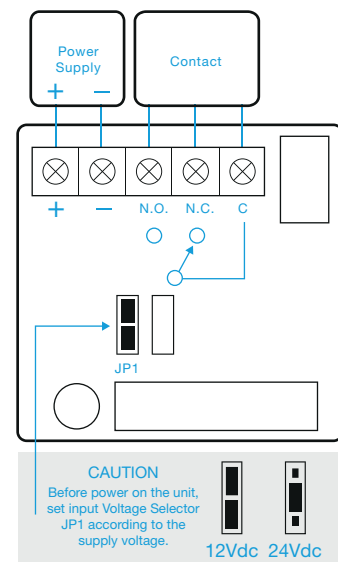
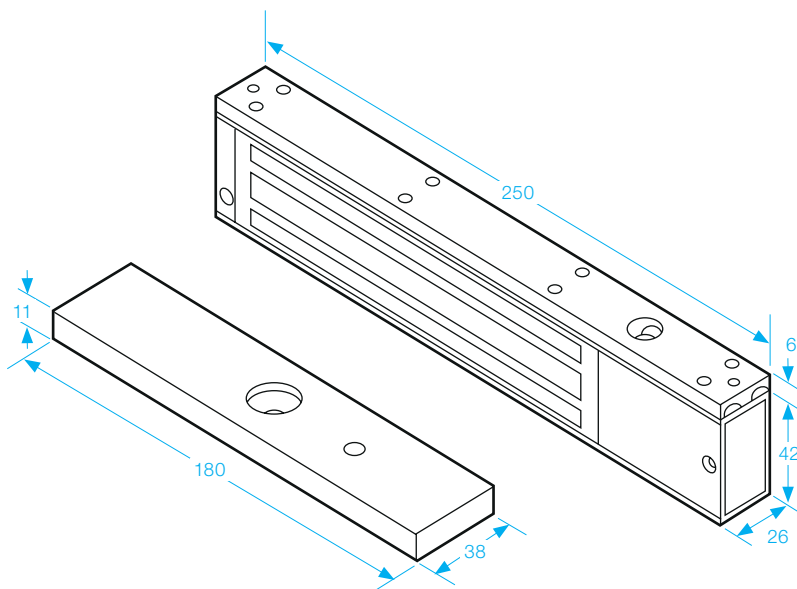

SPECIFICATION

- Voltage tolerance: $\pm 10\%$.
- Current draw: 480mA at 12Vdc, 240mA at 24Vdc (at temperature 20°C).
- Operating temperature: -10~55°C (14 to 131°F).
- Lock's surface temperature: Current temperature $\pm 20\%$ (when power is on).
- Magnetic bond sensor monitor output remotely monitors the door lock or unlock status. (N.C. Output-Door opened; N.O. Output-door closed) (SPDT rated 0.25A at 12Vdc).
- Humidity: 0~95% non-condensing.
- Aluminium housing, nickel plated armature.
- Weight: 2.0kg (approx).