

GS705-35

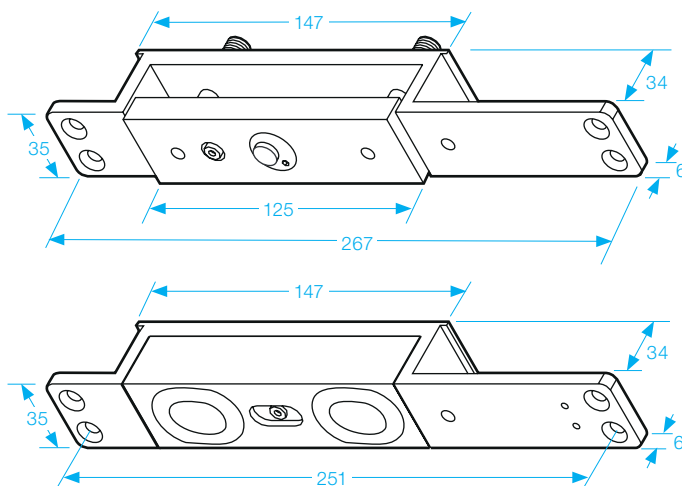

Shearlock

- Operating voltage 12~24Vdc
- Holding force up to 2,700lbs (1,226Kg) in shear
- Locking time delay: 1 to 6 seconds (Adjustable)



The Shear Locks may be wired to one or two different electrical configurations. An auto locking time delay is recommended for all installations to delay relocking 1-6 seconds after initial door closure. This will help ensure the door is fully closed and at a rest to ensure optimum alignment before the Shear Lock is energised.

MAGNET BOND SENSOR OUTPUT

N.C. output while door is unlocked;
N.O. output while door is locked by the electromagnetic lock

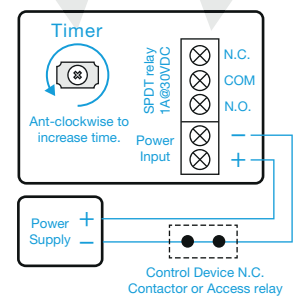

Caution: make sure that the (+) and (-) wires are connected correctly. Failure to observe polarity will result in a short circuit and is not covered by the products warranty.

SPECIFICATION

- Voltage tolerance: $\pm 10\%$.
- Current draw:
Pull in: 1.9A, Holding: 0.4A at 12Vdc.
Pull in: 1.2A, Holding: 0.3A at 24Vdc.
- Operating temperature: $-30\sim 55^{\circ}\text{C}$ (-22 to 131°F).
- Lock's surface temperature: Current temperature $\pm 20\%$ (when power is on).
- Magnetic bond sensor monitor output remotely monitors the door lock or unlock status. (N.C. Output-Door opened; N.O. Output-door closed) (SPDT rated 1A at 30Vdc).
- Humidity: 0~95% non-condensing.
- Horizontal or vertical installation.
- Special Zinc finish for magnet and armature plate.
- Housing black powder coated.
- Weight: 2.2kg (approx).