

# GK231M-L LEFT HAND

# GK231M-R RIGHT HAND

## Monitored Electric Release

- Operating voltage 12 or 24Vdc
- Fail-Safe
- 1500lbs holding force
- 500lbs sideload
- 1 Hour UK fire certificate



FIRE RESISTANT



STAINLESS STEEL



500 LBS SIDELOAD



UK FIRE TESTED

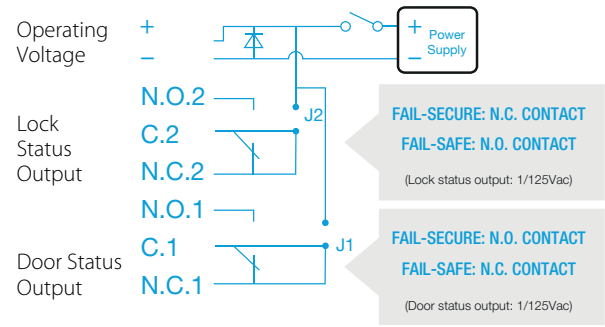
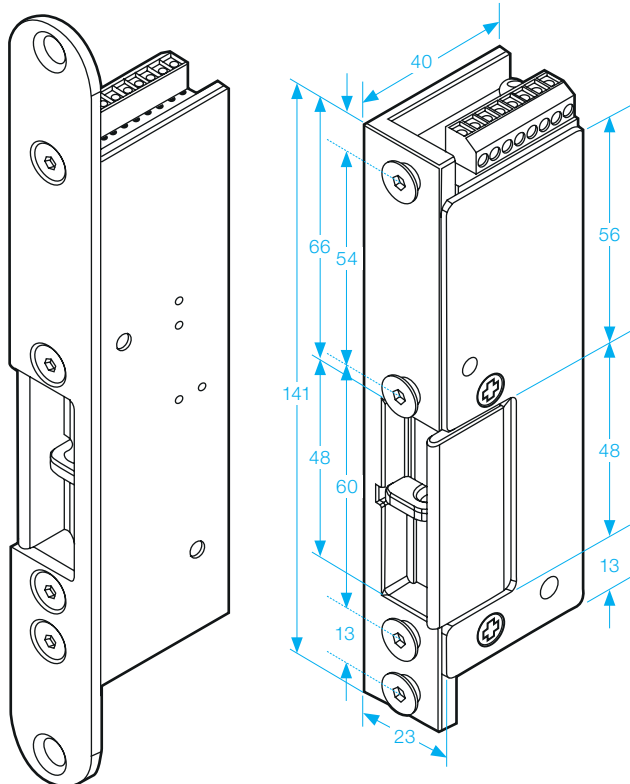

**SPECIFICATION**

- Voltage tolerance:  $\pm 20\%$ .
- Current draw: 280mA at 12Vdc, 140mA at 24Vdc (at temperature 20°C).
- Operating temperature: -10~45°C (14 to 131°F).
- Lock's surface temperature: Current temperature  $\pm 20\%$  (when power is on).
- Humidity: 0~95% non-condensing.
- Life rating of solenoid valve: 250,000 cycles
- Keeper width: 48mm
- Latch throw: 15mm (GK233: 8mm)
- Material: Stainless Steel
- 1500lbs jaw strength pull testing.
- Weight: 673g