

# PH450 UNMONITORED

# PH450M MONITORED

## Door Handle Magnet

- Operating voltage 12~24Vdc
- Aluminium
- Fail-Safe (*Power to Lock*)
- Holding force up to 600lbs (272Kg)

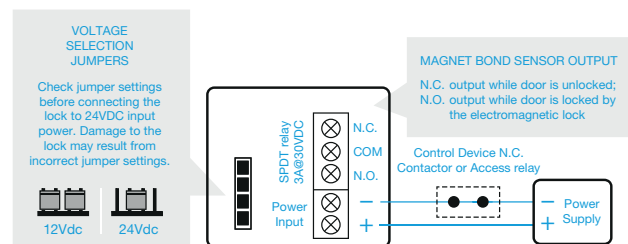
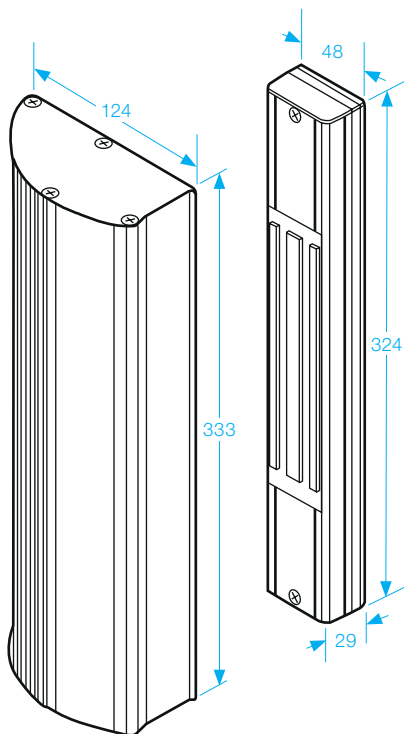

### SPECIFICATION

- Voltage tolerance:  $\pm 15\%$ .
- Current draw: 500mA at 12Vdc (at temperature 20°C).
- Operating temperature: -10~55°C (14 to 131°F).
- Lock's surface temperature: Current temperature  $\pm 20\%$  (when power is on).
- Magnetic bond sensor monitor output remotely monitors the door lock or unlock status. (N.C. Output-Door opened; N.O. Output-door closed) (SPDT rated 3A at 12Vdc).
- Humidity: 0~95% non-condensing.
- Special Zinc finish for magnet and armature plate.
- Weight: 2.0kg (approx).