

A10060 Unmonitored

A10060DS Unmonitored with Door Status

Unmonitored Double Standard Magnet

- Operating voltage 12~24Vdc (*Selectable*)
- Aluminium housing
- Holding force up to 2 x 1200lbs (*544Kg*)
- Electro-less nickel plated armature



OPTIONS

A500BP



A520S



A500ZL



A500ZLDC



A500AL



500CL



GDB14

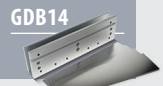

A10EXTP



LD-SM-SC

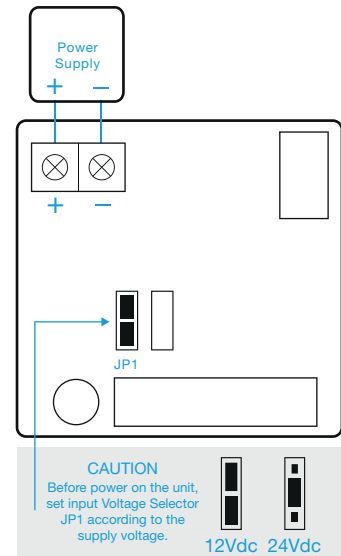
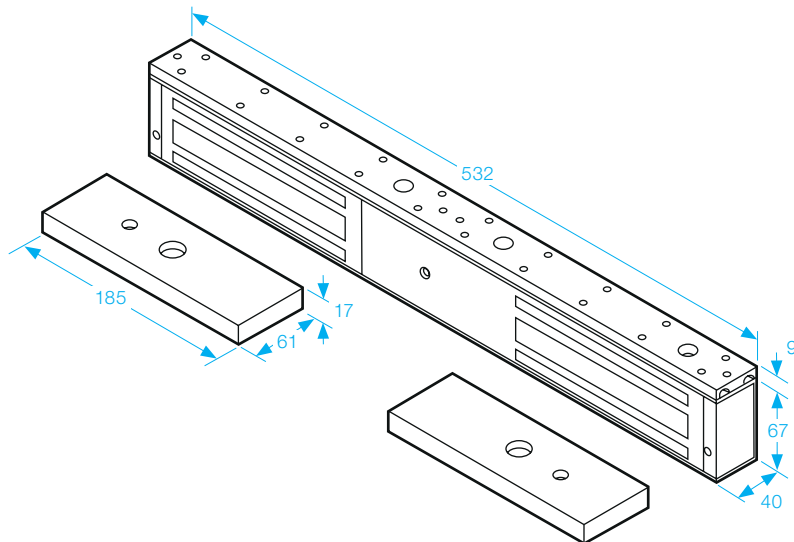

SPECIFICATION

- Voltage tolerance: $\pm 10\%$.
- Current draw: 420mA at 12Vdc, 210mA at 24Vdc (at temperature 20°C).
- Operating temperature: -10~55°C (14 to 131°F).
- Lock's surface temperature: Current temperature $\pm 20\%$ (when power is on).
- Humidity: 0~95% non-condensing.
- Aluminium housing, nickel plated armature.
- Weight: 9.3kg (approx).