

EM350 UNMONITORED

EM350M MONITORED

Midi Magnet

- Operating voltage 12~24Vdc
- Aluminium
- Holding force up to 850lbs (386Kg)

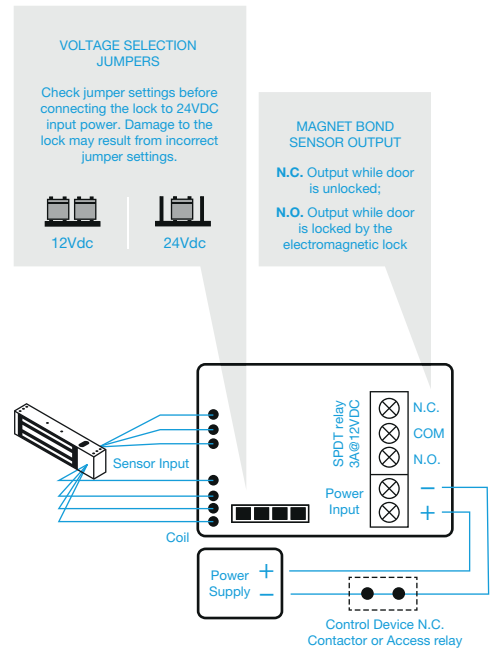
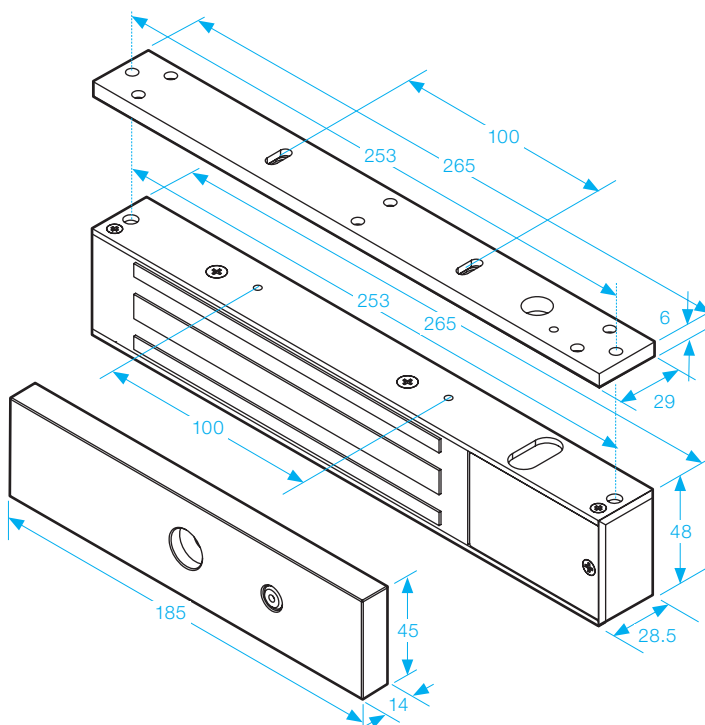

SPECIFICATION

- Voltage tolerance: ±15%.
- Current draw: 500mA at 12Vdc, 250mA at 24Vdc (at temperature 20°C).
- Operating temperature: -10 to 55°C (14 to 131°F).
- Lock's surface temperature: Current temperature ± 20% (when power is on).
- Magnetic bond sensor monitor output remotely monitors the door lock or unlock status. (N.C. Output-Door opened; N.O. Output door closed) (SPDT rated 3A at 12Vdc).
- Humidity: 0 to 95% non-condensing.
- Special Zinc finish for magnet and armature plate.
- Weight: 5.0kg (approx).