

GD870S-12 12 VDC**GD870S-24** 24 VDC**Door Retaining Magnet**

- Operating voltage 12 or 24Vdc
- Up to 100lbs (45kg) holding force
- Override switch
- Surface mount
- White powder-coat finish

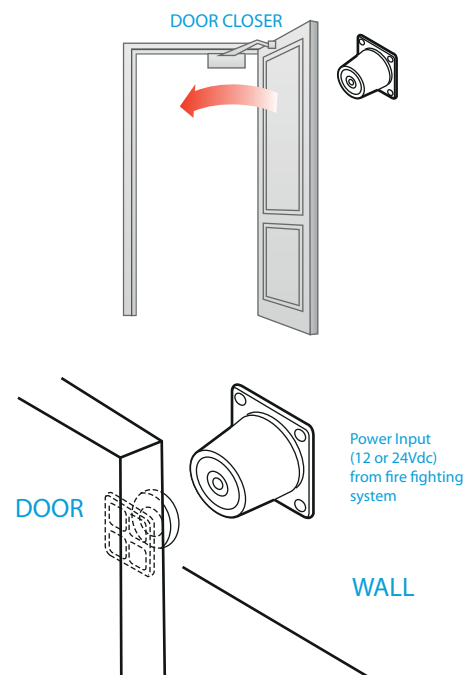
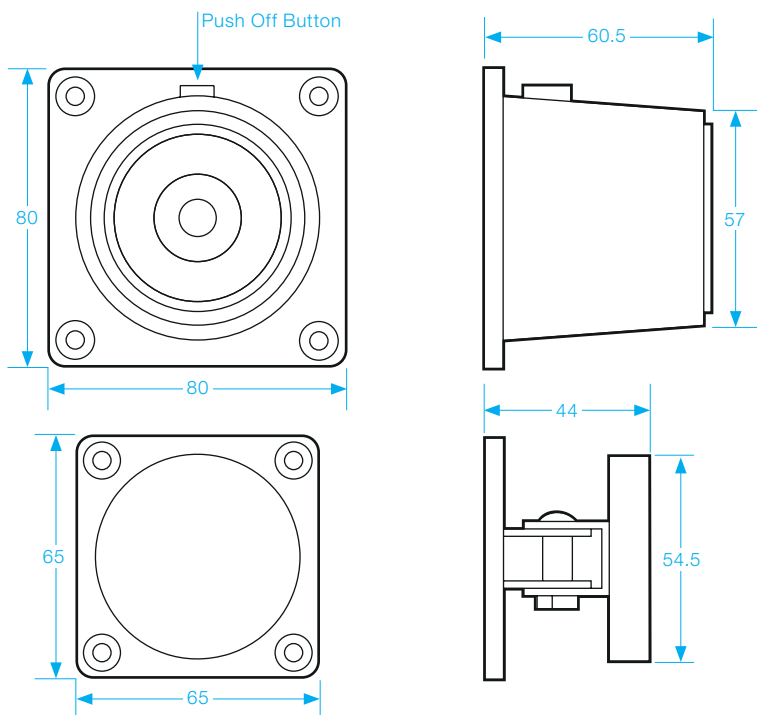

FIRE
TESTED
- EN1155 -

**SPECIFICATION**

- Voltage tolerance: $\pm 15\%$.
- Current draw: 125mA at 12Vdc, 60mA at 24Vdc (at temperature 20°C).
- Operating temperature: -10~45°C (14 to 131°F).
- Humidity: 0~95% non-condensing.
- Weight: 380g (approx).