



## GD830F-12 12 VDC

## GD830F-24 24 VDC

### Door Retaining Magnet

- Operating voltage 12Vdc
- Black powder-coat finish
- Fire tested: EN1155
- Up to 80lbs (36kg) holding force
- Over-ride switch
- Floor mount



FIRE  
TESTED  
- EN1155 -

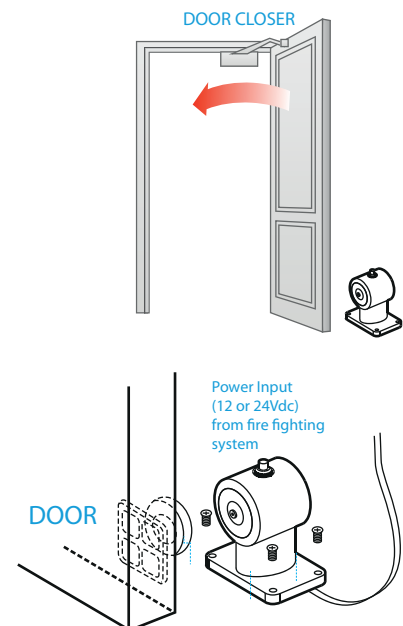
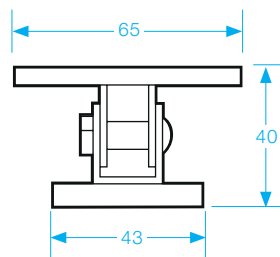
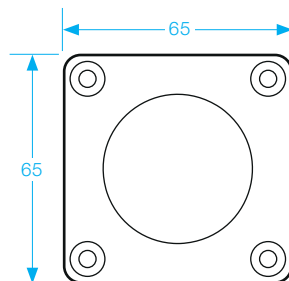
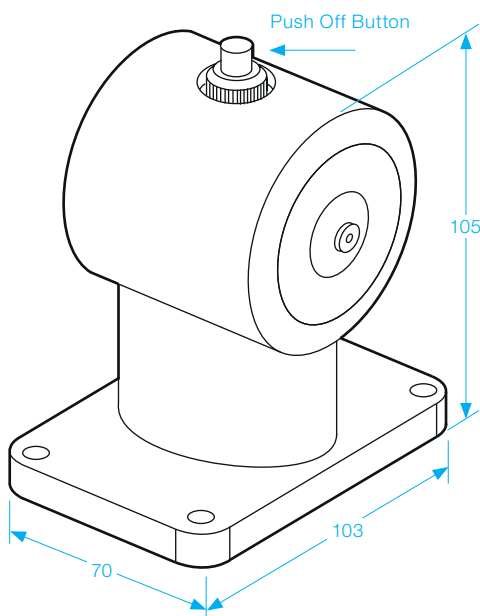

#### SPECIFICATION

- Voltage tolerance:  $\pm 15\%$ .
- Current draw: 130mA at 12Vdc, 60mA at 24Vdc (at temperature 20°C).
- Operating temperature: -10~45°C (14 to 131°F).
- Humidity: 0~95% non-condensing.
- Weight: 380g (approx).