

19002

Door Retaining Magnet

- Operating voltage 24Vdc
- Stainless Steel
- ABS cover
- Up to 120lbs (55kg) holding force
- Fire tested and certified to BS EN 1155 and CE marked
- Zero residual force
- Surface mount to standard BS wiring boxes
- Heavy duty construction
- 2 year warranty



STAINLESS
STEEL



FIRE
TESTED
- EN1155 -

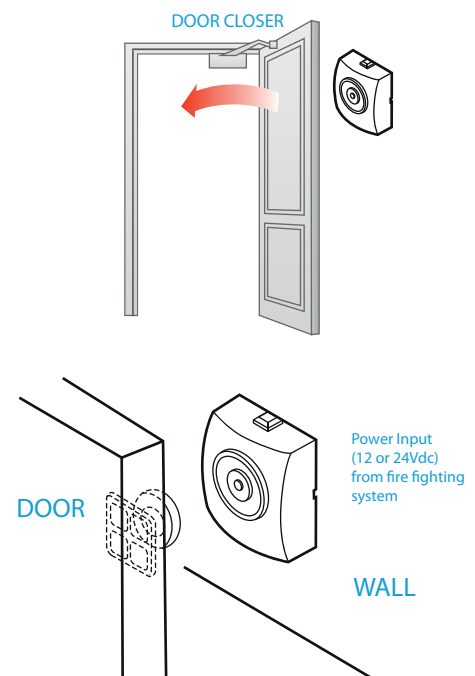
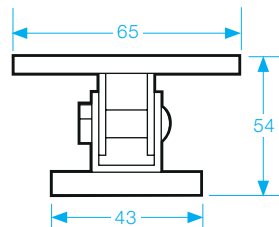
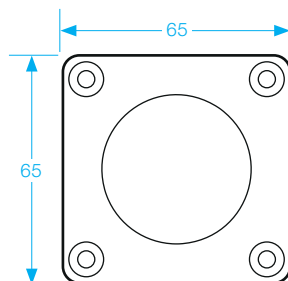
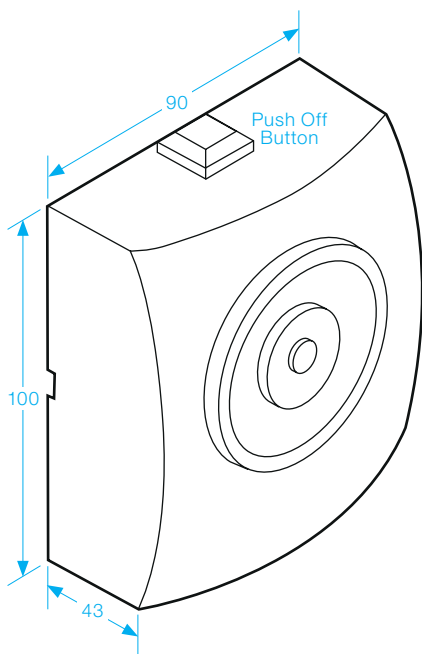

SPECIFICATION

- Voltage tolerance: $\pm 15\%$.
- Current draw: 125mA at 12Vdc, 60mA at 24Vdc (at temperature 20°C).
- Operating temperature: -10~45°C (14 to 131°F).
- Lock's surface temperature: Current temperature $\pm 20\%$ (when power is on).
- Bond sensor output (SPDT rated 3A at 125Vac).
- Humidity: 0~95% non-condensing.
- Stainless Steel face plate.
- Armature plate to be ordered separately.
- Electromagnet protected against residual magnetism.