

EB195

Electric Dropbolt

- Operating voltage 12~24Vdc
- Stainless Steel
- Fail-Safe (*Power to Lock*)
- Vandal resistant
- Built-in logical circuitry
- Auto-relocking timer delay:
0, 3, 6 or 9 seconds



VANDAL RESISTANT



STAINLESS STEEL

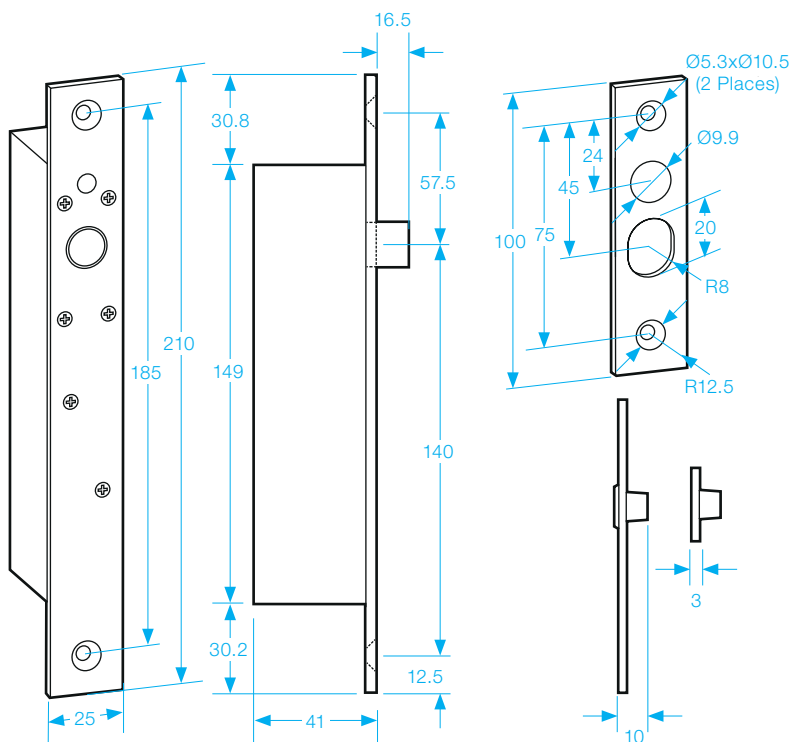
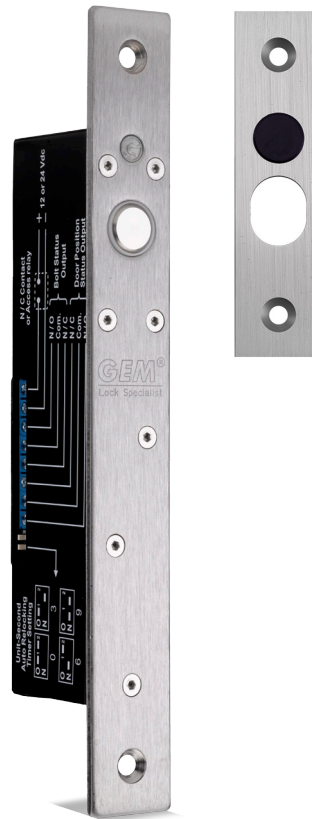

AUTO RELOCKING TIMER SETTINGS

Use jumpers to adjust the time between 0 to 9 seconds for door locking time delay. This is the time, which takes the dropbolt to automatically lock after the door is closed.

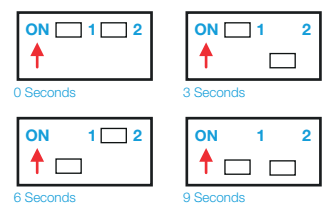

SPECIFICATION

- Voltage tolerance: $\pm 10\%$.
- Current draw: Pull in 0.9A, Holding 0.3A at 12Vdc (at temperature 20°C).
- Operating temperature: -10~45°C (14 to 131°F).
- Lock's surface temperature: Current temperature $\pm 20\%$ (when power is on).
- Magnetic bolt status output indicates bolt locked or unlocked status (SPDT rated 3A at 30Vdc).
- Humidity: 0~95% non-condensing.
- Horizontal or vertical installation.
- Face plate material: Stainless Steel
- Tested to 500,000 cycles.
- Weight: 0.6kg (approx).