

# GS705-35

# GS705-30

## Shearlock

- Operating voltage 12~24Vdc
- Holding force up to 2,700lbs (1,226Kg) in shear
- Locking time delay: 1 to 6 seconds (Adjustable)

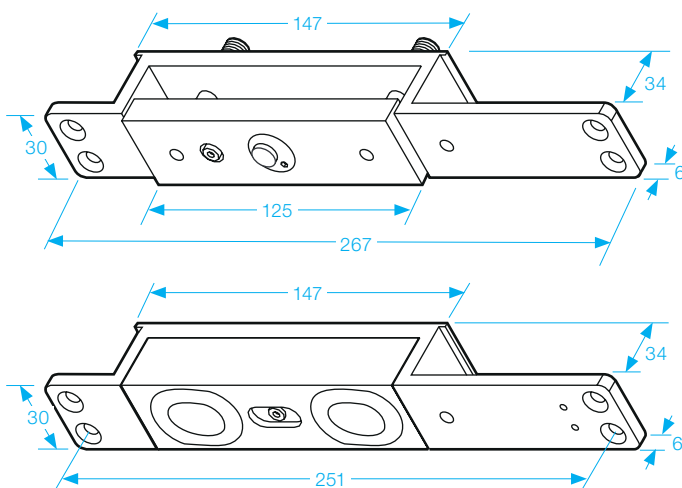

The Shear Locks may be wired to one or two different electrical configurations. An auto locking time delay is recommended for all installations to delay relocking 1-6 seconds after initial door closure. This will help ensure the door is fully closed and at a rest to ensure optimum alignment before the Shear Lock is energised.

**MAGNET BOND SENSOR OUTPUT**  
N.C. output while door is unlocked;  
N.O. output while door is locked by the electromagnetic lock

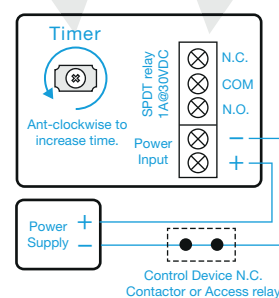

Caution: make sure that the (+) and (-) wires are connected correctly. Failure to observe polarity will result in a short circuit and is not covered by the products warranty.

### SPECIFICATION

- Voltage tolerance:  $\pm 10\%$ .
- Current draw:

#### GS705-35

Pull in: 1.9A, Holding: 0.4A at 12Vdc.  
Pull in: 1.2A, Holding: 0.3A at 24Vdc.

#### GS705-30

Pull in: 2.2A, Holding: 0.5A at 12Vdc.  
Pull in: 1.4A, Holding: 0.3A at 24Vdc.

- Operating temperature:  $-30\sim 55^{\circ}\text{C}$  ( $-22$  to  $131^{\circ}\text{F}$ ).
- Lock's surface temperature: Current temperature  $\pm 20\%$  (when power is on).
- Magnetic bond sensor monitor output remotely monitors the door lock or unlock status. (N.C. Output-Door opened; N.O. Output-door closed) (SPDT rated 1A at 30Vdc).

- Humidity: 0~95% non-condensing.
- Horizontal or vertical installation.
- Special Zinc finish for magnet and armature plate.
- Housing black powder coated.
- Weight: 1.8kg (approx).