



# 1500 Series

## Electric Lock

- Operating voltage 12 or 24Vdc  
(*Selectable*)
- 2,204lbs holding force (1,000Kg)
- Symetrical
- Adjustable jaw
- Suits upvc frames

PRODUCT	VOLTAGE	TOLERANCE	AMPS	OHMS
1510	12VAC	43	1,08	8,000
1510	12VDC	11-13	0,72	15,000
1510	24VDC	22-25	0,35	75,000
1511	12VDC	11-13	0,29	40,000
1511	24VDC	22-25	0,16	140,000

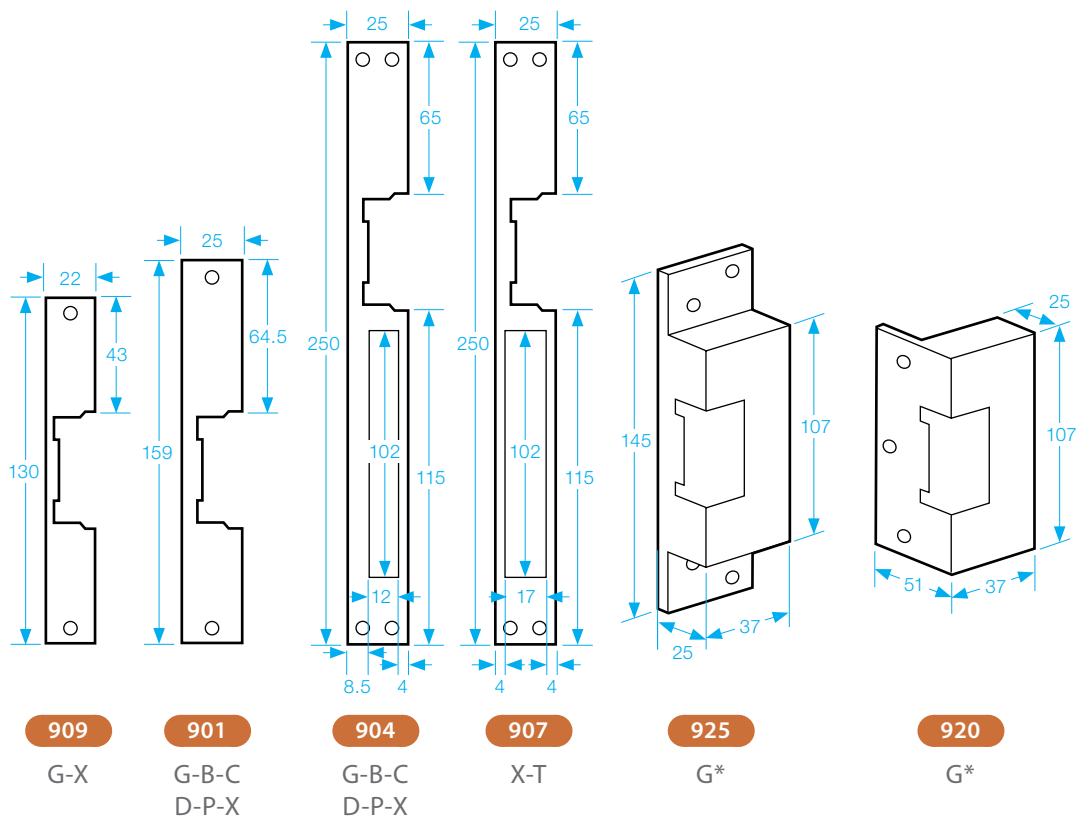

<b>G</b>	<b>B</b>	<b>C</b>	<b>D</b>	<b>P</b>	<b>X</b>	<b>T</b>	<b>N</b>
GREY STEEL	ALUM. BRONZE	ALUM. WHITE	ALUM. GOLD	ALUM. SILVER	STAINLESS STEEL	BRASS	BLACK IRON